



BALI
BAIN DE SOLEIL



+ PRODUIT

- Grande **stabilité** : 6 points d'appui au sol
- Haute **résistance à la corrosion** : conception multi-matériaux, aluminium & textylène
- **Ultra confort** : dossier haut , 4 positions & soutien ergonomique des jambes
- Facilité **d'usage & d'entretien** : roulettes intégrées, empilable



- Toile traitement anti uv, anti bactéries
- Toile haute qualité, indéformable
- Séchage rapide, facile à nettoyer



Confort ergonomique



Cadre polypropylène
teinté masse



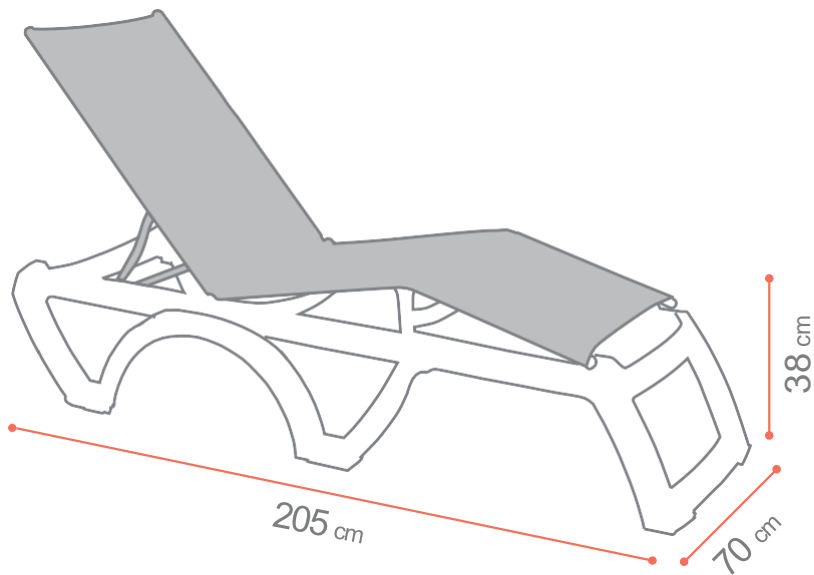

+ Aluminium
+ Alluminio
+ Aluminium

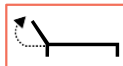

x16

12,45
Kg



Anthracite / T42 Straw
29 401 002



Anthracite / T2 Capuccino
44 279 002



Anthracite / T9 Écru
47 099 002



Anthracite / T18 Anthracite
47 043 002



Taupe / T21 Taupe
47 057 181



Taupe / T42 Straw
29 401 181



Bois / T9 Écru
47 099 008

STRUCTURE TOILE

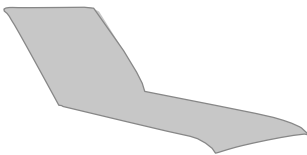

x 2
5 Kg



T18 Anthracite
ZBU8-SAV

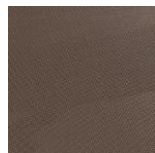

T21 Taupe
ZBU9-SAV



T9 Écru
ZBV0-SAV

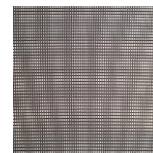

T2 Capuccino
ZBU7-SAV

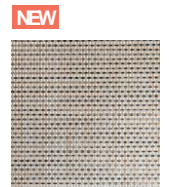

T42 Straw
ZC11-SAV