



LEGS GX2.0  
FOLDING

NEW



## DESIGN & PERFORMANCE

The new generation of GX2 feet has been designed to resist the harshest outdoor environments aggressive: sea fronts or snow-covered areas, the decisive advantages for professional outdoor furniture.

## + PRODUCT

- Design & colours :  
4 trendy colours for every style of terrace
- Complete range: standard, high and double legs
- High resistance to corrosion :  
sea front use - multi-material design
- Folding leg  
Grosfillex system tested
- Made in France : availability & warranty



Grosfillex system  
Safety lock on opening and closing



Folding leg



Leg and tray screws supplied

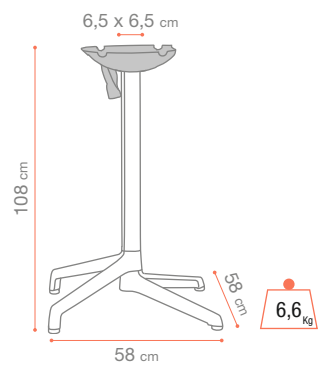
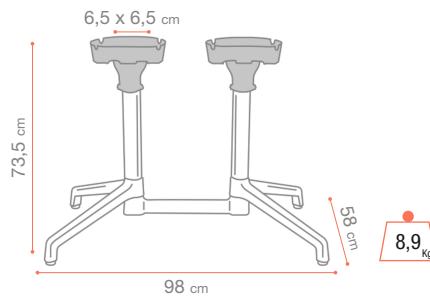
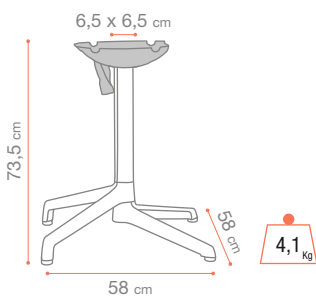

	ø70	60x70	70x70	80x80	110x70	120x80
X2.0	•	•	•	•		
X2.0 HIGH	•	•	•	•		
X2.0 DOUBLE					•	•

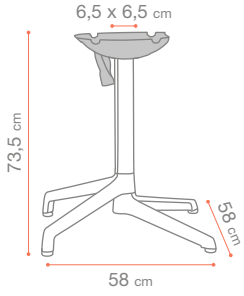

Charcoal  
U3 901 002



Platinum grey  
U3 901 289



Havane  
U3 901 011



Terracotta  
U3 901 814

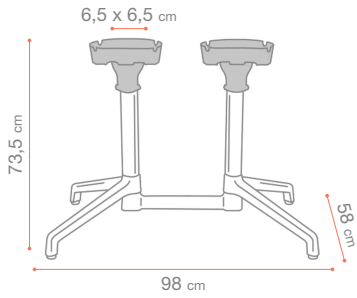

Charcoal  
U4 101 002



Platinum grey  
U4 101 289



Havane  
U4 101 011



Terracotta  
U4 101 814

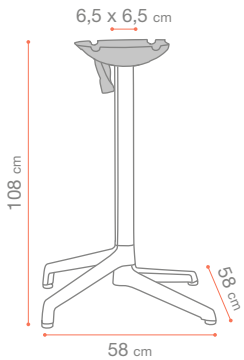

Charcoal  
U4 001 002



Platinum grey  
U4 001 289



Havane  
U4 001 011



Terracotta  
U4 001 814



\* Complies with European standards EN 581-1/3 : product tested for safety, resistance and stability for collective use.

## SPARE PARTS

PRODUCT	Reference
TUBE LEG X2 STD CHARCOAL	ZCK2002
TUBE LEG X2 STD HAVANE	ZCK2011
TUBE LEG X2 STD PLATINIUM GREY	ZCK2289
TUBE LEG X2 STD TERRACOTTA	ZCK2814
TUBE LEG X2 HT CHARCOAL	ZCK3002
TUBE LEG X2 HT HAVANE	ZCK3011
TUBE LEG X2 HT PLATINIUM GREY	ZCK3289
TUBE LEG X2 HT TERRACOTTA	ZCK3814
SET OF 4 PADS	ZC08